

## G5-M4-Lesson 1

1. A group of students measured the height of their bean sprout to the nearest quarter inch. Draw a line plot to represent their data:

$2\frac{1}{2}$ ,  $1\frac{1}{4}$ , 2,  $3\frac{1}{2}$ ,  $2\frac{1}{4}$ , 2,  $2\frac{1}{2}$ , 2,  $2\frac{1}{2}$ ,  $2\frac{1}{4}$ ,  $3\frac{1}{4}$

I can put an X above the number line for each measurement in this set of data.

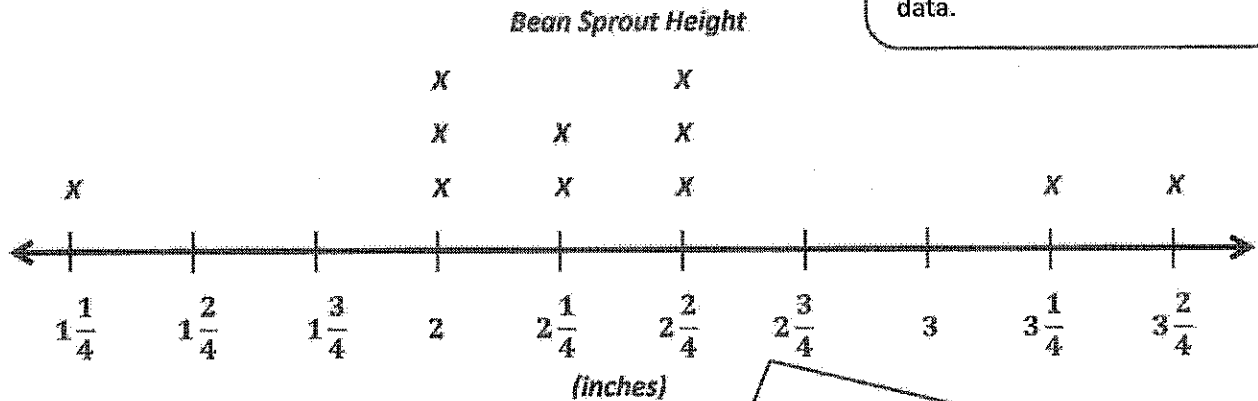

Since the data set includes values of both half, quarter, and whole inches, I can draw a number line that shows values between  $1\frac{1}{4}$  and  $3\frac{2}{4}$  and all of the  $\frac{1}{4}$  inches in between.

2. Answer the following questions.

- a. Which bean sprout is the tallest?

*The tallest sprout is  $3\frac{1}{2}$  inches.*

- b. Which bean sprout is the shortest?

*$1\frac{1}{4}$  inches.*

- c. Which measurement is the most frequent?

*The most frequent values are 2 inches and  $2\frac{1}{2}$  inches.*

Once my line plot is created, I can use it to help me answer these questions.

*Most frequent* means the value listed the most times. Since both 2 and  $2\frac{1}{2}$  were listed three times, both values are considered most frequent.

- d. What is the total height of all the bean sprouts?

*The total height of all the values is 26 inches.*

I made sure to add all eleven values. For example, I had to add 2 three times. I checked my answer by adding the values in the list and then the values on the number line to make sure both sums were the same.

G5-M4-Lesson 2

1. Draw a picture to show the division. Express your answer as a fraction.

a.  $1 \div 3 = 3 \text{ thirds} \div 3 = 1 \text{ third} = \frac{1}{3}$

$3 \div 3 = 1$   
Therefore, 3 thirds  $\div$  3 = 1 third.



I can think about  $1 \div 3$  as 1 cracker being shared equally by 3 people. Each person gets  $\frac{1}{3}$  of the cracker.

b.  $2 \div 5 = 10 \text{ fifths} \div 5 = 2 \text{ fifths} = \frac{2}{5}$

$10 \div 5 = 2$   
Therefore, 10 fifths  $\div$  5 = 2 fifths.

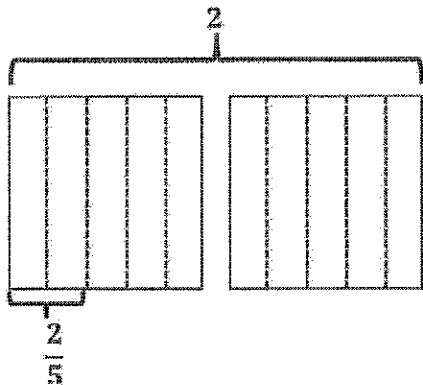

If 2 crackers were shared equally by 5 people, each person would get  $\frac{2}{5}$  of a cracker.

2. Fill in the blanks to make true number sentences.

a.  $15 \div 4 = \frac{15}{4}$

I can write a division expression as a fraction.

b.  $\frac{5}{3} = \underline{5} \div \underline{3}$

I can interpret a fraction as a division expression.

c.  $2\frac{1}{2} = \underline{5} \div \underline{2}$

I can express this mixed number as a fraction greater than 1.  
 $2\frac{1}{2} = \frac{5}{2}$

If 5 crackers were shared equally by 2 people, each person would get 5 halves, or  $2\frac{1}{2}$  crackers.

G5-M4-Lesson 3

1. Fill in the chart.

Division Expression	Unit Form	Improper Fraction	Mixed Number	Standard Algorithm (Write your answer in whole numbers and fractional units. Then check.)
a. $3 \div 2$	$6 \text{ halves} \div 2 =$ $3 \text{ halves}$	$\frac{3}{2}$	$1\frac{1}{2}$	<div style="display: flex; justify-content: space-between;"> <div style="text-align: center;"> <math>\frac{1}{2}</math>  <math>2 \overline{) 3}</math>  <math>\underline{-2}</math>  <math>1</math> </div> <div style="text-align: left;"> <p>Check:</p> <math>2 \times 1\frac{1}{2}</math>  <math>= 1\frac{1}{2} + 1\frac{1}{2}</math>  <math>= 3</math> </div> </div>

I can visualize the drawings I made in the previous lesson. 3 crackers are shared equally by 2 people. I could partition each cracker into 2 equal parts and then share the 6 halves.

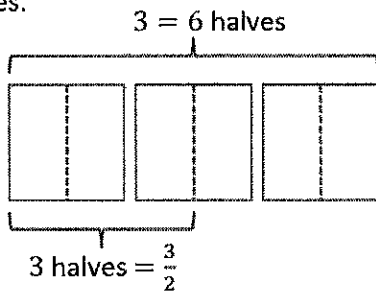

I can think of this another way too. Since there are 3 crackers being shared equally by 2 people, each person could get 1 whole cracker and  $\frac{1}{2}$  of another.

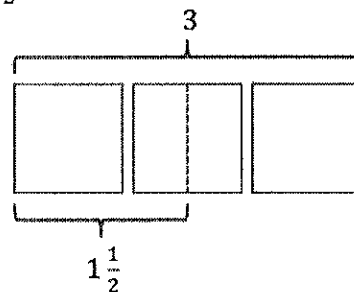

Division Expression	Unit Form	Improper Fraction	Mixed Numbers	Standard Algorithm (Write your answer in whole numbers and fractional units. Then check.)
b. $5 \div 3$	$15 \text{ thirds} \div 3 = 5 \text{ thirds}$	$\frac{5}{3}$	$1\frac{2}{3}$	$  \begin{array}{r}  1\frac{2}{3} \\  3 \overline{) 5} \\  \underline{-3} \phantom{0} \\  2  \end{array}  $ <i>Check:</i> $  \begin{aligned}  &3 \times 1\frac{2}{3} \\  &= 1\frac{2}{3} + 1\frac{2}{3} + 1\frac{2}{3} \\  &= 3\frac{6}{3} \\  &= 3 + 2 \\  &= 5  \end{aligned}  $

This time I am given the mixed number. I know that  $1\frac{2}{3}$  is the same as  $\frac{3}{3} + \frac{2}{3}$ , which is equal to  $\frac{5}{3}$ . I can think of  $\frac{5}{3}$  as a division expression,  $5 \div 3$ .

The standard algorithm makes sense. If there were 5 crackers being shared equally by 3 people, each person could get 1 whole cracker, and then the remaining 2 crackers would be partitioned into 3 equal parts and shared as thirds. I can visualize one way to model this scenario:

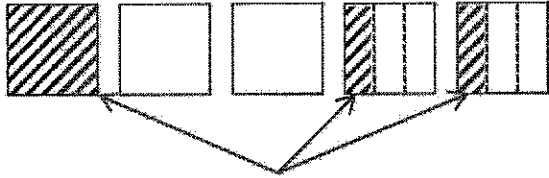

Each person gets 1 whole cracker and  $\frac{2}{3}$  of a cracker.

### G5-M4-Lesson 4

Draw a tape diagram to solve. Express your answer as a fraction. Show the addition sentence to support your answer.

$$5 \div 4 = \frac{5}{4} = 1\frac{1}{4}$$

I can think of the expression  $5 \div 4$  as 5 crackers being shared equally by 4 people. This unit here represents how much 1 person gets.

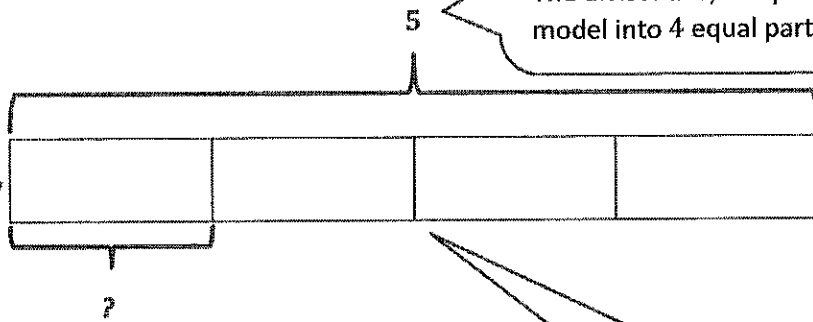

I can model  $5 \div 4$  by drawing a tape diagram. The whole tape represents the dividend, 5. The divisor is 4, so I partition the model into 4 equal parts, or units.

$$4 \text{ units} = 5$$

$$1 \text{ unit} = 5 \div 4 = \frac{5}{4} = 1\frac{1}{4}$$

Now that I've divided, I know that each of these four units has a value of  $1\frac{1}{4}$ .

My tape diagram shows me that the 4 parts, or units, are equal to 5. So, I can find the value of 1 unit by dividing,  $5 \div 4$ .

$$\begin{array}{r} 1\frac{1}{4} \\ 4 \overline{) 5} \\ \underline{-4} \\ 1 \end{array}$$

Check:

$$\begin{aligned} 4 \times 1\frac{1}{4} &= 1\frac{1}{4} + 1\frac{1}{4} + 1\frac{1}{4} + 1\frac{1}{4} \\ &= 4 + \frac{4}{4} \\ &= 5 \end{aligned}$$

## G5-M4-Lesson 5

Kenneth divided 15 cups of whole wheat flour equally to make 4 loaves of bread.

- a. How much whole wheat flour went into each loaf?

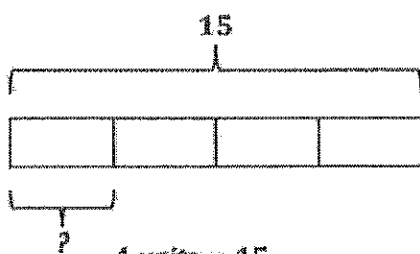

The whole tape represents 15 cups of flour. Since the flour is used to make 4 equal loaves of bread, I partitioned the tape into 4 equal units, or parts.

$$1 \text{ unit} = 15 \div 4 = \frac{15}{4} = 3\frac{3}{4}$$

$\frac{15}{4}$  is equal to  $\frac{4}{4} + \frac{4}{4} + \frac{4}{4} + \frac{3}{4}$ , which is the same as  $3\frac{3}{4}$ .

Kenneth used  $3\frac{3}{4}$  cups of whole wheat flour for each loaf of bread.

- b. How many cups of whole wheat flour are in 3 loaves of bread?

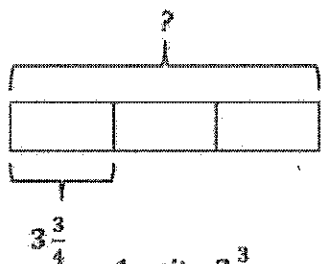

Now that I know how much flour is in one loaf of bread, I can multiply that amount by 3 to answer this question.

$$\begin{aligned} 1 \text{ unit} &= 3\frac{3}{4} \\ 3 \text{ units} &= 3 \times 3\frac{3}{4} \\ &= 3\frac{3}{4} + 3\frac{3}{4} + 3\frac{3}{4} \\ &= 9 + \frac{9}{4} \\ &= 9 + 2\frac{1}{4} \\ &= 11\frac{1}{4} \end{aligned}$$

Since Kenneth used a total of 15 cups of flour for 4 loaves, I could have also used subtraction to find the amount used in 3 loaves.

$$15 - 3\frac{3}{4} = 12 - \frac{3}{4} = 11\frac{1}{4}$$

There are  $11\frac{1}{4}$  cups of whole wheat flour in 3 loaves.

### G5-M4-Lesson 6

1. Find the value of the following.

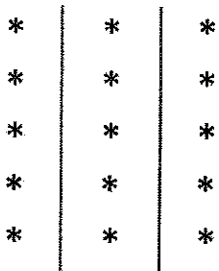

The array shows a total of 15 stars. Each column represents 1 third.

$$\frac{1}{3} \text{ of } 15 = 5$$

To find 2 thirds, I can count the number of stars in two columns.

$$\frac{2}{3} \text{ of } 15 = 10$$

$$\frac{3}{3} \text{ of } 15 = 15$$

$\frac{3}{3}$  represents *all* of the stars, or the amount found in all 3 columns.

2. Find  $\frac{3}{4}$  of 12. Draw a set, and shade to show your thinking.

The total in the array has to be 12. Since I'm trying to find fourths, I can draw a row of 4 circles. I can draw a second row of 4 circles and continue drawing rows until I have a total of 12 circles.

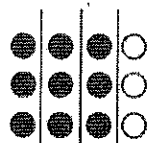

$$\frac{3}{4} \text{ of } 12 = 9$$

I shaded 3 out of the 4 columns. I counted how many circles I shaded to find the answer.

I drew vertical lines to clearly show the fourths. Each column represents  $\frac{1}{4}$  of 12.



3. How does knowing  $\frac{1}{3}$  of 18 help you find  $\frac{2}{3}$  of 18? Draw a picture to explain your thinking.

I know I need a set of 18. Since I'm finding a third of 18, I drew rows of 3.

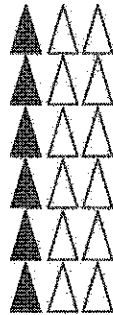

From my drawing, I know  $\frac{1}{3}$  of 18 is 6.

$\frac{2}{3}$  of 18 is twice as much as  $\frac{1}{3}$  of 18.

$$\frac{2}{3} \text{ of } 18 = 12.$$

$\frac{1}{3}$  of 18 is 6, so  $\frac{2}{3}$  of 18 is  $2 \times 6$ , or 12.  
 $\frac{3}{3}$  of 18 would be  $3 \times 6$ , or 18.

4. Michael collected 21 sports cards.  $\frac{3}{7}$  of the cards are baseball cards. How many cards are not baseball cards?

The whole set is 21 cards. In order to show sevenths, I can draw 7 rectangles in a column and then continue drawing columns until I show all 21 cards.

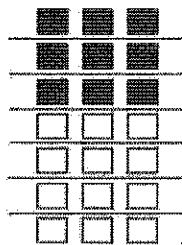

12 of the cards are not baseball cards.

I drew horizontal lines to show the sevenths. I shaded in  $\frac{3}{7}$  to show the collection of baseball cards.

The question asked how many cards were *not* baseball cards, so I counted  $\frac{4}{7}$ , or 12, rectangles to get my answer.

In the other examples, I drew rows first. In this question, I drew columns first. Either way is correct, and either way will show my thinking accurately.

### G5-M4-Lesson 7

Solve using a tape diagram.

a.  $\frac{1}{5}$  of 25 = 5

I can draw a tape diagram and label the whole as 25. I need to find fifths, so I partition the whole into five units, or parts.

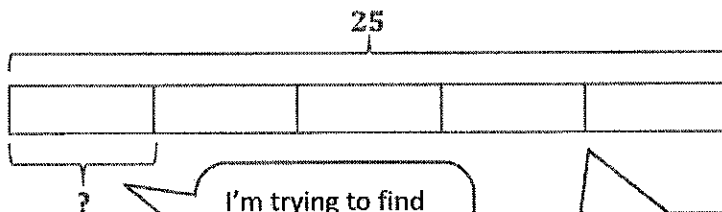

5 units = 25

1 unit =  $25 \div 5 = \frac{25}{5} = 5$

I'm trying to find 1 fifth. That's what the question mark shows.

I can visualize each unit of the tape diagram having a value of 5: 5, 10, 15, 20, 25.

The tape diagram shows that 5 units equal 25. If I want to find the value of 1 unit, I need to divide 25 by 5.

I interpreted  $25 \div 5$  as a fraction:  $\frac{25}{5}$ . Then I simplified  $\frac{25}{5}$  as 5.

b.  $\frac{3}{4} \times 16 = 12$

I can interpret  $\frac{3}{4} \times 16$  as  $\frac{3}{4}$  of 16.

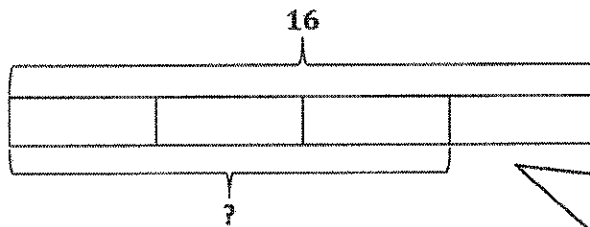

4 units = 16

1 unit =  $16 \div 4 = \frac{16}{4} = 4$

3 units =  $3 \times 4 = 12$

I can visualize each unit of the tape diagram having a value of 4: 4, 8, 12, 16.

The tape diagram shows the whole as 16 partitioned into 4 parts. I found the value of one unit and then multiplied that by three to find the value of 3 units.

c.  $\frac{5}{6}$  of a number is 25. What's the number?

I can interpret this as  $\frac{5}{6}$  of ? = 25.

In this problem, I am given the value of some parts, and I need to find the value of the whole.

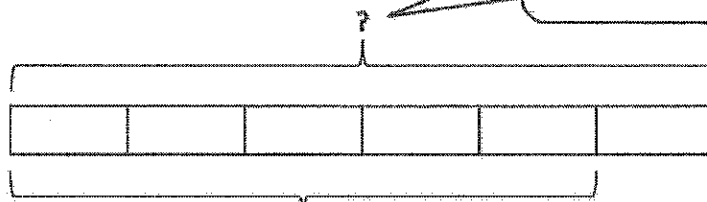

25

$\frac{5}{6} = 25$ , so these 5 units have a value of 25. If I can find the value of 1 unit, I can find the value of 6 units, or the whole.

5 units = 25

1 unit =  $25 \div 5 = \frac{25}{5} = 5$

6 units =  $6 \times 5 = 30$

The number is 30.

I can visualize each unit of the tape diagram having a value of 5: 5, 10, 15, 20, 25, 30.

### G5-M4-Lesson 8

1. Rewrite the following expressions as shown in the example.

Example:  $\frac{4}{7} + \frac{4}{7} + \frac{4}{7} = \frac{3 \times 4}{7} = \frac{12}{7}$

a.  $\frac{3}{2} + \frac{3}{2} + \frac{3}{2}$

$\frac{3}{2} + \frac{3}{2} + \frac{3}{2} = \frac{3 \times 3}{2} = \frac{9}{2}$

b.  $\frac{2}{5} + \frac{2}{5} + \frac{2}{5} + \frac{2}{5}$

$\frac{2}{5} + \frac{2}{5} + \frac{2}{5} + \frac{2}{5} = \frac{4 \times 2}{5} = \frac{8}{5}$

This expression is repeatedly adding 2 fifths. I can write it as a multiplication expression.

This is the same as  $4 \times \frac{2}{5}$ , or  $\frac{4 \times 2}{5}$ .

2. Solve each problem in two different ways. Express your answer in simplest form.

a.  $\frac{2}{5} \times 30$

$\frac{2}{5} \times 30 = \frac{2 \times 30}{5} = \frac{60}{5} = 12$

$\frac{2}{5} \times 30 = \frac{2 \times \cancel{30}_5}{\cancel{5}_1} = 12$

In this method, I simplified after I multiplied.

In this method, I see that 30 and 5 have a common factor of 5. I can divide both 30 and 5 by 5, and now I can think of the fraction as  $\frac{2 \times 6}{1}$ .

This method involved some larger numbers that are challenging to do mentally.

Dividing by a common factor of 8 made this method much simpler! I can do this mentally.

b.  $32 \times \frac{7}{8}$

$32 \times \frac{7}{8} = \frac{32 \times 7}{8} = \frac{224}{8} = 28$

$32 \times \frac{7}{8} = \frac{\cancel{32}_8 \times 7}{\cancel{8}_1} = 28$

3. Solve any way you choose.

$\frac{3}{4} \times 60$

$\frac{3}{4}$  hour = \_\_\_ minutes

$\frac{3}{4} \times 60 = \frac{3 \times 60}{4} = \frac{180}{4} = 45$

$\frac{3}{4}$  hour = 45 minutes

Since there are 60 minutes in an hour, this is the expression I can use to find how many minutes are in  $\frac{3}{4}$  of an hour.

I could have solved by simplifying before I multiplied.

$\frac{3}{4} \times 60 = \frac{3 \times \cancel{60}_4}{\cancel{4}_1} = 45$

## G5-M4-Lesson 9

1. Convert. Show your work using a tape diagram or an equation.

a.  $\frac{3}{4}$  year = \_\_\_\_\_ months

$$\frac{3}{4} \text{ year} = \frac{3}{4} \times 1 \text{ year}$$

$$= \frac{3}{4} \times 12 \text{ months}$$

$$= \frac{36}{4} \text{ months}$$

$$= 9 \text{ months}$$

I can think of  $\frac{3}{4}$  year as  $\frac{3}{4}$  of 1 year.

I can rename 1 year as 12 months.

I can do this in my head:  $\frac{3}{4} \times 12 = \frac{3 \times 12}{4} = \frac{36}{4}$ .

b.  $\frac{5}{6}$  hour = \_\_\_\_\_ minutes

$$\frac{5}{6} \text{ hour} = \frac{5}{6} \times 1 \text{ hour}$$

$$= \frac{5}{6} \times 60 \text{ minutes}$$

$$= \frac{300}{6} \text{ minutes}$$

$$= 50 \text{ minutes}$$

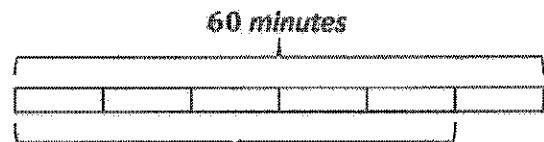

I can use a tape diagram to show that I'm trying to find  $\frac{5}{6}$  of 60 minutes.

2.  $\frac{2}{3}$  of a yardstick was painted blue. How many feet of the yardstick were painted blue?

$$\frac{2}{3} \text{ yard} = \text{_____ feet}$$

$$= \frac{2}{3} \times 1 \text{ yard}$$

$$= \frac{2}{3} \times 3 \text{ feet}$$

$$= \frac{6}{3} \text{ feet}$$

$$= 2 \text{ feet}$$

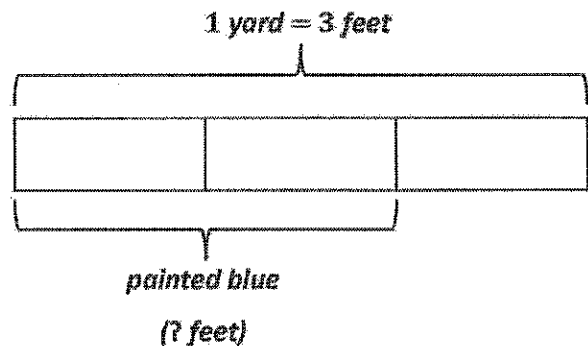

2 feet of the yardstick are painted blue.

G5-M4-Lesson 10

Evaluate means solve, so I need to find the value of the unknown.

1. Write expressions to match the diagrams. Then, evaluate.

a.

I also could have written  $(23 - 8) \times \frac{1}{3}$ .  
Both expressions are correct.

23 - 8, or 15, is the whole.

23 - 8

$$\begin{aligned} &\frac{1}{3} \times (23 - 8) \\ &= \frac{1}{3} \times 15 \\ &= \frac{15}{3} \\ &= 5 \end{aligned}$$

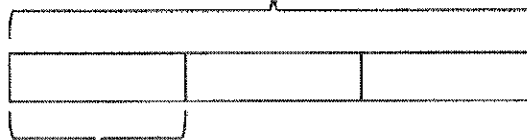

The question mark shows that I'm trying to find 1 third of the whole.

The question mark tells me I need to find the value of the whole.

b.

$$\begin{aligned} &4 \times \left(\frac{4}{5} - \frac{1}{3}\right) \\ &= 4 \times \left(\frac{12}{15} - \frac{5}{15}\right) \\ &= 4 \times \frac{7}{15} \\ &= \frac{28}{15} \\ &= 1 \frac{13}{15} \end{aligned}$$

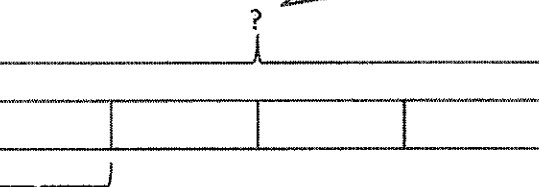

$\frac{4}{5} - \frac{1}{3}$

This 1 unit is equal to  $\frac{1}{4}$  of the whole. If I multiply it by 4, I can find the value of the whole.

In order to subtract, I need to make like units.

I have to find the difference before I multiply by 4.

2. Circle the expression(s) that give the same product as  $4 \times \frac{2}{5}$ . Explain how you know.

a.  $5 \div (2 \times 4)$

*This expression is equal to  $5 \div 8$ , not  $8 \div 5$ .*

b.  $2 \div 5 \times 4$

*$2 \div 5$  is equal to  $\frac{2}{5}$ .  $\frac{2}{5} \times 4 = 4 \times \frac{2}{5}$*

c.  $4 \times 2 \div 5$

*This expression is equal to  $8 \div 5$ , which is  $\frac{8}{5}$  or  $1\frac{3}{5}$ .*

d.  $4 \times \frac{5}{2}$

*This expression does have 4 as one of the factors, but  $\frac{5}{2}$  is not equivalent to  $\frac{2}{5}$ .*

I can determine which expressions are equivalent to  $4 \times \frac{2}{5}$  without evaluating. However, to check my thinking, I can solve.

$$4 \times \frac{2}{5} = \frac{4 \times 2}{5} = \frac{8}{5} = 1\frac{3}{5}$$

3. Write an expression to match, and then evaluate.

a.  $\frac{1}{3}$  the sum of 12 and 21

The word *sum* tells me that 12 and 21 are being added.

In order to find  $\frac{1}{3}$  of the sum, I can multiply by  $\frac{1}{3}$  or divide by 3.

$$\begin{aligned} & \frac{1}{3} \times (12 + 21) \\ &= \frac{1}{3} \times 33 \\ &= \frac{33}{3} \\ &= 11 \end{aligned}$$

b. Subtract 5 from  $\frac{1}{7}$  of 49.

I need to be careful with subtraction! Even though the beginning of the expression says to subtract 5, I need to find  $\frac{1}{7}$  of 49 first.

$$\begin{aligned} & \frac{1}{7} \times 49 - 5 \\ &= \frac{49}{7} - 5 \\ &= 7 - 5 \\ &= 2 \end{aligned}$$

4. Use  $<$ ,  $>$ , or  $=$  to make true number sentences without calculating. Explain your thinking.

a.  $(17 \times 41) + \frac{5}{4}$   $<$   $\frac{7}{4} + (17 \times 41)$

Since both expressions show  $(17 \times 41)$ , I only have to compare the parts being added to this product.

$\frac{5}{4} < \frac{7}{4}$ . Therefore, the expression on the left is less than the expression on the right.

In both expressions, one of the factors is  $\frac{3}{4}$ . I only have to compare the other factors.

I know that  $15 + 18 = 33$  and  $3 \times 11 = 33$ . The second factors are equivalent too.

b.  $\frac{3}{4} \times (15 + 18)$   $=$   $(3 \times 11) \times \frac{3}{4}$

Since both factors are equivalent, these expressions are equal.



## G5-M4-Lesson 11

Use the RDW (Read, Draw, Write) method to solve.

1. Janice and Adam cooked a 1 lb package of spinach. Janice ate  $\frac{1}{2}$  of the spinach, and Adam ate  $\frac{1}{4}$  of the spinach. What fraction of the package was left? How many ounces were left?

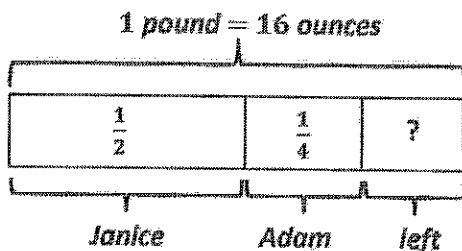

I can add the parts that Janice and Adam ate together to find out what is left over.

$$\begin{aligned} & \frac{1}{2} + \frac{1}{4} \\ &= \frac{4}{8} + \frac{2}{8} \\ &= \frac{6}{8} \end{aligned}$$

$$1 - \frac{6}{8} = \frac{2}{8}$$

$\frac{2}{8}$  of the package was left.

$\frac{2}{8}$  of 16 ounces:

$$\begin{aligned} & \frac{2}{8} \times 16 \\ &= \frac{2 \times 16}{8} \\ &= \frac{32}{8} \\ &= 4 \end{aligned}$$

$\frac{2}{8}$  of the package is left. I want to find out how many ounces that is, so I multiply  $\frac{2}{8}$  by 16 ounces.

4 ounces of spinach were left.

2. Using the tape diagram below, create a story problem about a school. Your story must include a fraction.

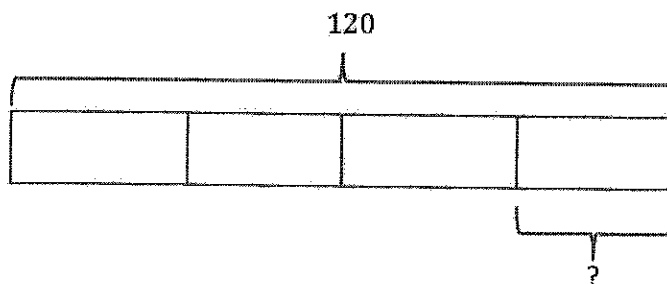

I can interpret this model as  $\frac{1}{4}$  of 120.

*Crestview Elementary School has 120 fifth graders. Three-fourths of them ride the bus to school. The rest of the fifth-grade students walk to school. What fraction of the fifth-grade students walk to school?*

## G5-M4-Lesson 12

Solve using the RDW (Read, Draw, Write) method.

1. Beth ran her leg of a relay race in  $\frac{3}{5}$  the amount of time it took Margaret. Wayne ran his leg of the relay race in  $\frac{2}{3}$  the time it took Beth. Margaret finished the race in 30 minutes. How long did it take for Wayne to finish his part of the race?

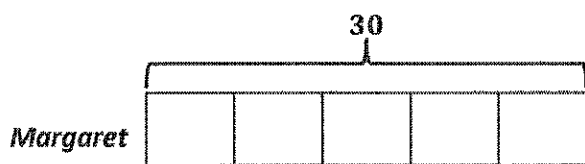

Since Beth's time was  $\frac{3}{5}$  of Margaret's, I can partition Margaret's time into 5 equal units. Now I can show that Beth's time is  $\frac{3}{5}$  of Margaret's.



Wayne's time was  $\frac{2}{3}$  of Beth's time. 3 units represent Beth's time, so I can show Wayne's time with 2 units.  $\frac{2}{3}$  of 3 units is 2 units.

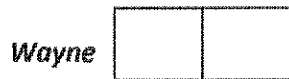

$$5 \text{ units} = 30$$

$$1 \text{ unit} = 30 \div 5 = 6$$

I can use my tape diagram to help me solve. I know that Margaret finished in 30 minutes; therefore, the 5 units representing Margaret's time are equal to 30 minutes.

$$2 \text{ units} = 2 \times 6 = 12$$

Wayne finished the race in 12 minutes.

I can visualize each unit in the tape diagram being equal to 6 minutes.

Wayne's time is equal to 2 units of 6 minutes each, or 12 minutes.

2. Create a story problem about a brother and sister and the money they spend at a deli whose solution is given by the expression  $\frac{1}{3} \times (7 + 8)$ .

*Two siblings went to a deli. The sister had \$7.00, and her brother had \$8.00. They spent one-third of their combined money. How much money did they spend in the deli?*

The parentheses tell me to add first. In my story problem, I wrote that the siblings combined their money.

### G5-M4-Lesson 13

1. Solve. Draw a rectangular fraction model to show your thinking.

a. Half of  $\frac{1}{4}$  pan of brownies

Half of  $\frac{1}{4} = \frac{1}{8}$

$$\frac{1}{2} \times \frac{1}{4} = \frac{1}{8}$$

Seeing the word *of* reminds me of third grade when I learned that  $2 \times 3$  meant 2 groups of 3.

The problem tells me I have  $\frac{1}{4}$  pan of brownies. I can draw a whole pan. Then, I can shade and label  $\frac{1}{4}$  of the pan.

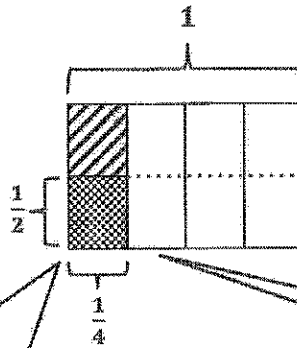

Since I want to model 1 half of the fourth of a pan, I can partition the fourth into 2 equal parts, or halves. I can shade  $\frac{1}{2}$  of the  $\frac{1}{4}$ .

My model shows me that  $\frac{1}{2}$  of  $\frac{1}{4}$  is equal to  $\frac{1}{8}$  of the pan of brownies.

b.  $\frac{1}{4} \times \frac{1}{4}$

$$\frac{1}{4} \times \frac{1}{4} = \frac{1}{16}$$

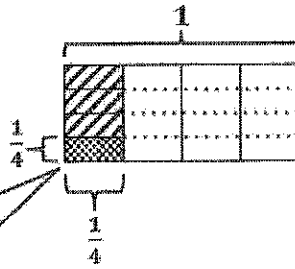

The part that is double-shaded shows  $\frac{1}{4}$  of  $\frac{1}{4}$ .

$$\frac{1}{4} \text{ of } \frac{1}{4} = \frac{1}{16}$$

2. The Guerra family uses  $\frac{3}{4}$  of their backyard for a pool.  $\frac{1}{3}$  of the remaining yard is used for a vegetable garden. The rest of the yard is grass. What fraction of the entire backyard is for the vegetable garden? Draw a picture to support your answer.

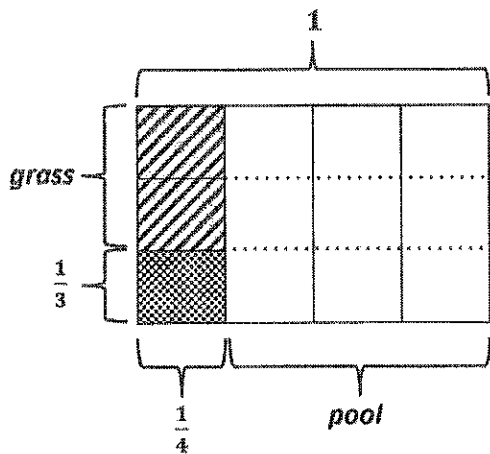

Since  $\frac{3}{4}$  of the backyard is a pool, that means  $\frac{1}{4}$  of the backyard is *not* a pool.

$$\frac{1}{3} \times \frac{1}{4} = \frac{1}{12}$$

$\frac{1}{12}$  of the backyard is a vegetable garden.

G5-M4-Lesson 14

1. Solve. Draw a rectangular fraction model to explain your thinking.

a.  $\frac{1}{3}$  of  $\frac{3}{5} = \frac{1}{3}$  of 3 fifths = 1 fifth

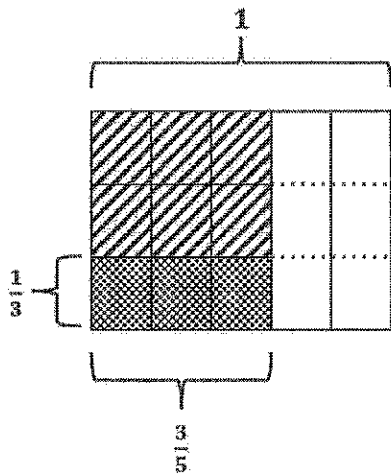

$\frac{1}{3}$  of 3 is 1.

$\frac{1}{3}$  of 3 bananas is 1 banana.

$\frac{1}{3}$  of 3 fifths is 1 fifth.

$$\frac{1}{3} \times \frac{3}{5} = \frac{3}{15} = \frac{1}{5}$$

I can model  $\frac{3}{5}$  by partitioning vertically first. Then to show  $\frac{1}{3}$  of  $\frac{3}{5}$ , I can partition with horizontal lines.

b.  $\frac{1}{2} \times \frac{3}{4}$

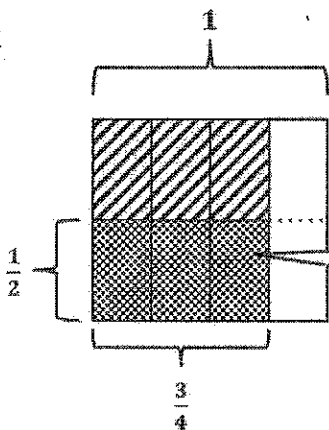

$$\frac{1}{2} \times \frac{3}{4} = \frac{3}{8}$$

My model shows me that  $\frac{1}{2}$  of  $\frac{3}{4}$  is  $\frac{3}{8}$ . The part here that is double-shaded shows the product, 3 eighths.

2. Kenny collects coins.  $\frac{3}{5}$  of his collection is dimes.  $\frac{1}{2}$  of the remaining coins are quarters. What fraction of Kenny's whole collection is quarters? Support your answer with a model.

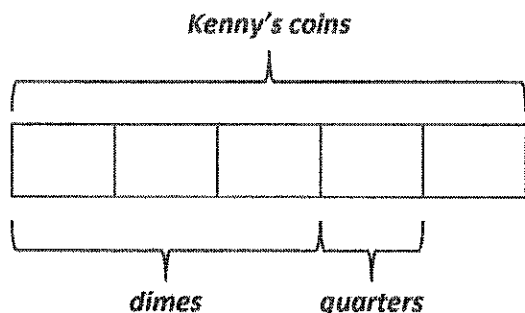

Since  $\frac{3}{5}$  of Kenny's collection is dimes, then  $\frac{2}{5}$  of the collection is not dimes. 1 half of that  $\frac{2}{5}$  is quarters.  
 $\frac{1}{2}$  of  $\frac{2}{5}$  is  $\frac{1}{5}$ .

$$\frac{1}{2} \times \frac{2}{5} = \frac{2}{10} = \frac{1}{5}$$

*One fifth of Kenny's coin collection is quarters.*

3. In Jan's class,  $\frac{3}{8}$  of the students take the bus to school.  $\frac{4}{5}$  of the non-bus riders walk to school. One half of the remaining students ride their bikes to school.

- a. What fraction of all the students walk to school?

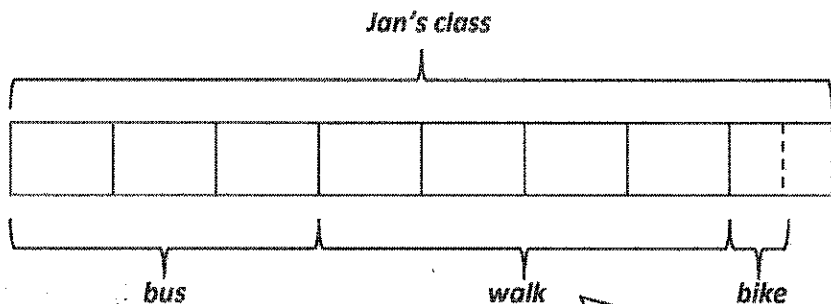

$\frac{4}{5}$  of 5 eighths = 4 eighths

$$\frac{4}{5} \times \frac{5}{8} = \frac{20}{40} = \frac{1}{2}$$

$\frac{1}{2}$  of all the students walk to school.

I can divide the whole class into 8 equal units to show that  $\frac{3}{8}$  of the students take the bus to school.

Since  $\frac{3}{8}$  ride the bus to school, then  $\frac{5}{8}$  do not ride the bus.  
 $\frac{4}{5}$  of  $\frac{5}{8}$  is  $\frac{4}{8}$ .

- b. What fraction of all the students ride their bikes to school?

$\frac{1}{2}$  of  $\frac{1}{8} = \frac{1}{16}$   
 $\frac{1}{16}$  of all the students bike to school.

After labeling the units that represent the students that walk or bus to school, there was only 1 unit, or  $\frac{1}{8}$  of the class, remaining. Half of those students bike to school.

G5-M4-Lesson 15

1. Solve. Draw a rectangular fraction model to explain your thinking. Then, write a multiplication sentence.

$\frac{2}{5}$  of  $\frac{2}{3}$

$\frac{2}{5} \times \frac{2}{3} = \frac{4}{15}$

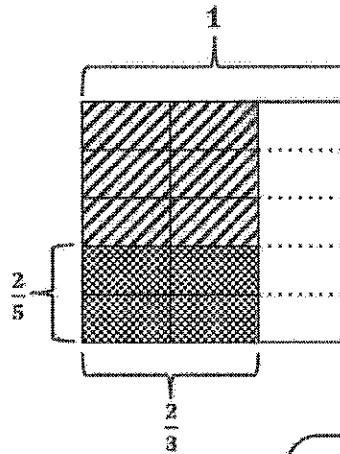

2. Multiply.

a.  $\frac{3}{8} \times \frac{2}{5}$

$\frac{3}{8} \times \frac{2}{5} = \frac{3 \times 2}{8 \times 5} = \frac{3 \times \cancel{2}}{\cancel{8} \times 5} = \frac{3}{20}$

The 2 in the numerator and the 8 in the denominator have a common factor of 2.

$2 \div 2 = 1$  and  $8 \div 2 = 4$

Now the numerator is  $3 \times 1$ , and the denominator is  $4 \times 5$ .

b.  $\frac{2}{5} \times \frac{10}{12}$

$\frac{2}{5} \times \frac{10}{12} = \frac{\cancel{2} \times \cancel{10}^2}{5 \times \cancel{12}_6} = \frac{2}{6}$

I was able to rename this fraction twice before multiplying. 5 and 10 have a common factor of 5.

And 2 and 12 have a common factor of 2.

Now the numerator is  $1 \times 2$ , and the denominator is  $1 \times 6$ .

G5-M4-Lesson 16

Solve and show your thinking with a tape diagram.

1. Heidi had 6 pounds of tomatoes from her garden. She used  $\frac{3}{4}$  of all the tomatoes to make sauce and gave  $\frac{2}{3}$  of the rest of the tomatoes to her neighbor. How many ounces of tomatoes did Heidi give to her neighbor?

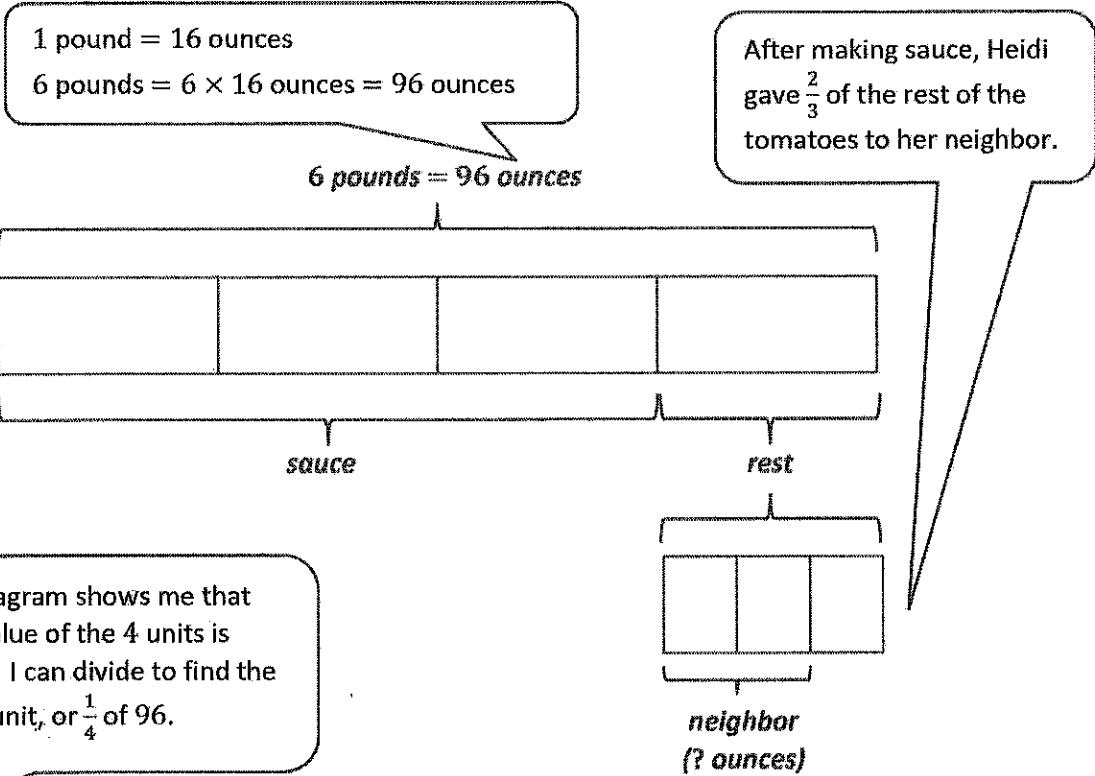

My tape diagram shows me that the total value of the 4 units is 96 ounces. I can divide to find the value of 1 unit, or  $\frac{1}{4}$  of 96.

4 units = 96  
1 unit =  $96 \div 4 = 24$

Now I know that Heidi had 24 ounces of tomatoes left after making sauce.

$\frac{2}{3}$  of 24 =  $\frac{2 \times 24}{3} = \frac{48}{3} = 16$

I can find  $\frac{2}{3}$  of 24 and know how many ounces Heidi gave to her neighbor.

When I look at my model, I can think of this another way. Heidi gave  $\frac{2}{3}$  of  $\frac{1}{4}$  to her neighbor.

$\frac{2}{3} \times \frac{1}{4} = \frac{2}{12} = \frac{1}{6}$

Heidi gave  $\frac{1}{6}$  of all the tomatoes to her neighbor.

$\frac{1}{6}$  of 96 = 16

Heidi gave her neighbor 16 ounces of tomatoes.



2. Tracey spent  $\frac{2}{3}$  of her money on movie tickets and  $\frac{3}{4}$  of the remaining money on popcorn and water. If she had \$4 left over, how much money did she have at first?

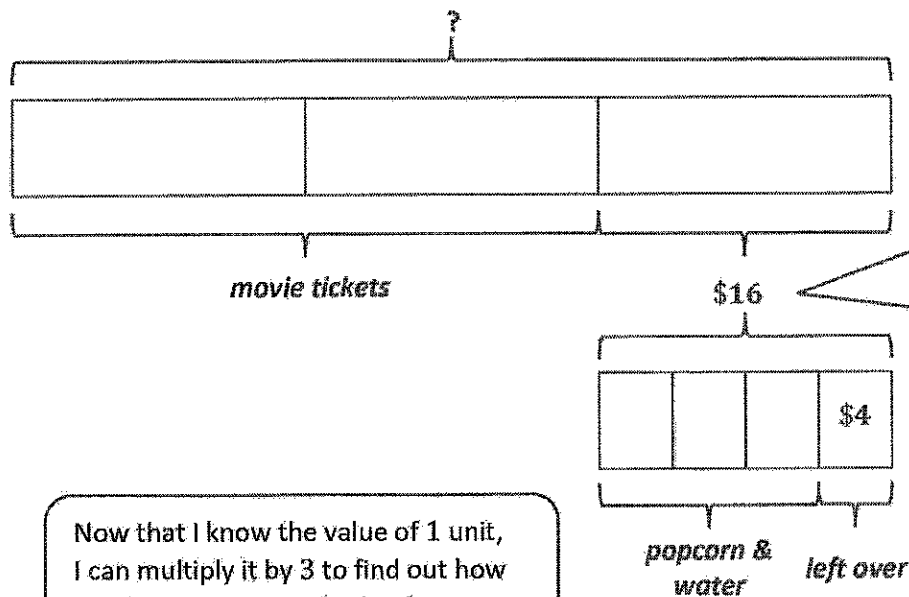

I can multiply 4 times \$4 to find out how much money Tracey had remaining after buying the movie tickets.

$4 \times \$4 = \$16$

Now that I know the value of 1 unit, I can multiply it by 3 to find out how much money Tracey had at first.

$1 \text{ unit} = \$16$

$3 \text{ units} = 3 \times \$16 = \$48$

Tracey had \$48 at first.

### G5-M4-Lesson 17

1. Multiply and model. Rewrite each expression as a multiplication sentence with decimal factors.

a.  $\frac{3}{10} \times \frac{2}{10}$   
 $= \frac{3 \times 2}{10 \times 10}$

Since the whole grid represents 1, each square represents  $\frac{1}{100}$ . 10 squares is equal to  $\frac{1}{10}$ .

$= \frac{6}{100}$

When multiplying fractions, I multiply the two numerators,  $3 \times 2$ , and the two denominators,  $10 \times 10$ , to get  $\frac{6}{100}$ .

I shade in  $\frac{2}{10}$  (20 squares vertically).

I shade in  $\frac{3}{10}$  of  $\frac{2}{10}$  (6 squares).

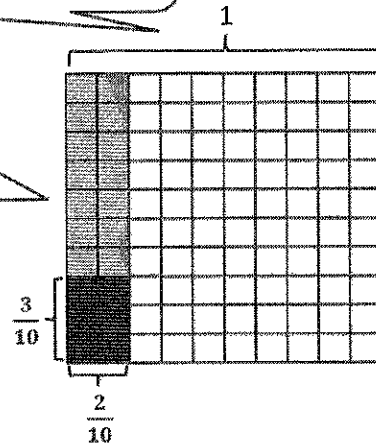

I label each whole grid as 1, and each square represents  $\frac{1}{100}$ .

b.  $\frac{3}{10} \times 1.2$   
 $= \frac{3}{10} \times \frac{12}{10}$   
 $= \frac{3 \times 12}{10 \times 10}$

I shade in 1 and  $\frac{2}{10}$  (120 squares vertically).

$= \frac{36}{100}$

I rename 1.2 as a fraction greater than one,  $\frac{12}{10}$ , and then multiply to get  $\frac{36}{100}$ .

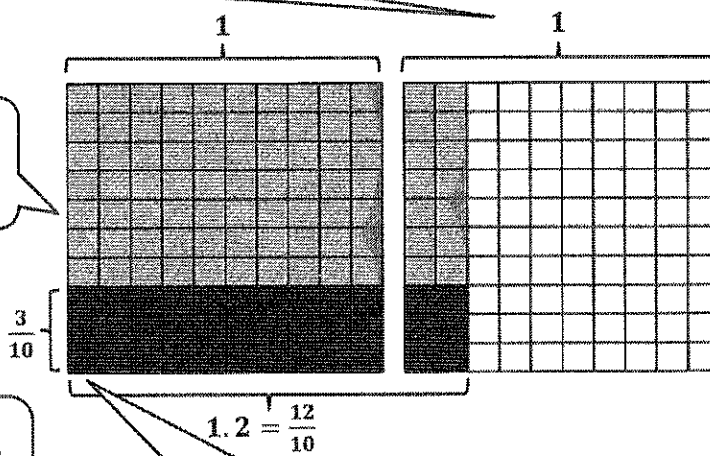

I shade in  $\frac{3}{10}$  of  $\frac{12}{10}$  (36 squares).

2. Multiply.

a.  $2 \times 0.6$

$$= 2 \times \frac{6}{10}$$

$$= \frac{2 \times 6}{10}$$

$$= \frac{12}{10}$$

$$= 1.2$$

I rewrite the decimal as a fraction and then multiply the two numerators and the two denominators to get  $\frac{12}{10}$ . Lastly, I write it as a mixed number if possible.

b.  $0.2 \times 0.6$

$$= \frac{2}{10} \times \frac{6}{10}$$

$$= \frac{2 \times 6}{10 \times 10}$$

$$= \frac{12}{100}$$

$$= 0.12$$

0.2 is 2 tenths, or  $\frac{2}{10}$ . After multiplying, the answer is  $\frac{12}{100}$ , or 0.12.

0.02 is 2 hundredths, or  $\frac{2}{100}$ . After multiplying, the answer is  $\frac{12}{1,000}$  or 0.012.

c.  $0.02 \times 0.6$

$$= \frac{2}{100} \times \frac{6}{10}$$

$$= \frac{2 \times 6}{100 \times 10}$$

$$= \frac{12}{1,000}$$

$$= 0.012$$

3. Sydney makes 1.2 liters of orange juice. If she pours 4 tenths of the orange juice in the glass, how many liters of orange juice are in the glass?

$$\frac{4}{10} \text{ of } 1.2 \text{ L}$$

$$\frac{4}{10} \times 1.2$$

$$= \frac{4}{10} \times \frac{12}{10}$$

$$= \frac{4 \times 12}{10 \times 10}$$

$$= \frac{48}{100}$$

$$= 0.48$$

To find 4 tenths of 1.2 liters, I multiply  $\frac{4}{10}$  times  $\frac{12}{10}$  to get  $\frac{48}{100}$ , or 0.48.

*There are 0.48 L of orange juice in the glass.*



2. A flower garden measures 2.75 meters by 4.2 meters.

a. Find the area of the flower garden.

$$2.75 \text{ m} \times 4.2 \text{ m} = 11.55 \text{ m}^2$$

The area of the flower garden is 11.55 square meters.

I multiply the length times the width to find the area of the garden.

$$\begin{array}{r}
 275 \text{ hundredths} \\
 \times 42 \text{ tenths} \\
 \hline
 550 \\
 11000 \\
 \hline
 11,550 \text{ thousandths}
 \end{array}$$

A hundredth times a tenth is a thousandth.

$$\frac{1}{100} \times \frac{1}{10} = \frac{1 \times 1}{100 \times 10} = \frac{1}{1,000}$$

b. The area of the vegetable garden is one and a half times that of the flower garden. Find the total area of the flower garden and the vegetable garden.

$$11.55 \text{ m}^2 \times 1.5 = 17.325 \text{ m}^2$$

$$11.55 \text{ m}^2 + 17.325 \text{ m}^2 = 28.875 \text{ m}^2$$

$$\begin{array}{r}
 1155 \text{ hundredths} \\
 \times 15 \text{ tenths} \\
 \hline
 5775 \\
 + 11550 \\
 \hline
 17,325 \text{ thousandths}
 \end{array}$$

I find the area of the vegetable garden by multiplying the flower garden's area by 1.5, or 15 tenths.

$$\begin{array}{r}
 11.550 \\
 + 17.325 \\
 \hline
 28.875
 \end{array}$$

I add the 2 areas together to find the total area.

The total area of the flower garden and the vegetable garden is 28.875 m<sup>2</sup>.

## G5-M4-Lesson 19

1. Convert. Express your answer as a mixed number, if possible.

a.  $9 \text{ in} = \underline{\hspace{1cm}} \text{ ft}$

$$9 \text{ in} = 9 \times 1 \text{ in}$$

$$= 9 \times \frac{1}{12} \text{ ft}$$

$$= \frac{9}{12} \text{ ft}$$

$$= \frac{3}{4} \text{ ft}$$

I know that 1 foot = 12 inches  
and 1 inch =  $\frac{1}{12}$  foot.

9 inches is equal to 9 times 1 inch. I can  
rename 1 inch as  $\frac{1}{12}$  foot and then multiply.

b.  $20 \text{ oz} = \underline{\hspace{1cm}} \text{ lb}$

$$20 \text{ oz} = 20 \times 1 \text{ oz}$$

$$= 20 \times \frac{1}{16} \text{ lb}$$

$$= \frac{20}{16} \text{ lb}$$

$$= 1 \frac{4}{16} \text{ lb}$$

$$= 1 \frac{1}{4} \text{ lb}$$

I know that 1 pound = 16 ounces  
and 1 ounce =  $\frac{1}{16}$  pound.

20 ounces is equal to 20 times 1 ounce. I  
can rename 1 ounce as  $\frac{1}{16}$  pound and then  
multiply.

2. Jack buys 14 ounces of peanuts.

What fraction of a pound of peanuts did Jack buy?

$$14 \text{ oz} = \underline{\hspace{1cm}} \text{ lb}$$

$$14 \text{ oz} = 14 \times 1 \text{ oz}$$

$$= 14 \times \frac{1}{16} \text{ lb}$$

$$= \frac{14}{16} \text{ lb}$$

$$= \frac{7}{8} \text{ lb}$$

1 pound = 16 ounces,  
and 1 ounce =  $\frac{1}{16}$  pound.

Jack bought  $\frac{7}{8}$  pound of peanuts.

## G5-M4-Lesson 20

Convert. Express the answer as a mixed number.

1.  $2\frac{2}{3}$  ft = \_\_\_\_ in

1 foot = 12 inches

$$2\frac{2}{3} \text{ ft} = 2\frac{2}{3} \times 1 \text{ ft}$$

$$= 2\frac{2}{3} \times 12 \text{ in}$$

$$= \frac{8}{3} \times 12 \text{ in}$$

$$= \frac{96}{3} \text{ in}$$

$$= 32 \text{ in}$$

I rename  $2\frac{2}{3}$  as a fraction greater than 1, or an improper fraction,  $\frac{8}{3}$ . Then, I multiply.

2.  $2\frac{7}{10}$  hr = \_\_\_\_ min

1 hour = 60 minutes

$$2\frac{7}{10} \text{ hr} = 2\frac{7}{10} \times 1 \text{ hr}$$

$$= 2\frac{7}{10} \times 60 \text{ min}$$

$$= (2 \times 60 \text{ min}) + \left(\frac{7}{10} \times 60 \text{ min}\right)$$

$$= (120 \text{ min}) + (42 \text{ min})$$

$$= 162 \text{ min}$$

I can use the distributive property. I multiply  $2 \times 60$  minutes and add that to the product of  $\frac{7}{10} \times 60$  minutes.

3. Charlie buys  $2\frac{1}{4}$  pounds of apples for a pie. He needs 50 ounces of apples for the pie. How many more pounds of apples does he need to buy?

I draw a whole tape diagram showing the total of 50 ounces of apples that Charlie needs for the pie.

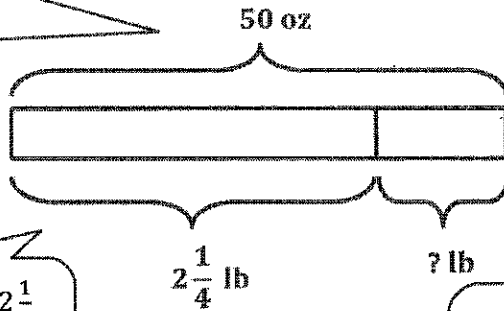

I draw and label a part  $2\frac{1}{4}$  pounds to show the apples Charlie bought.

I label the remaining part that Charlie needs with a question mark, to represent what I'm trying to find out.

$$2\frac{1}{4} \text{ lb} = \underline{\hspace{2cm}} \text{ oz}$$

$$\begin{aligned} 2\frac{1}{4} \text{ lb} &= 2\frac{1}{4} \times 16 \text{ oz} \\ &= \frac{9}{4} \times 16 \text{ oz} \\ &= 36 \text{ oz} \end{aligned}$$

I convert  $2\frac{1}{4}$  pounds to ounces by multiplying by 16.  $2\frac{1}{4}$  pounds is equal to 36 ounces.

$$\begin{array}{r} 4 \ 10 \\ \cancel{5} \ \cancel{0} \ \text{oz} \\ - \ 3 \ 6 \ \text{oz} \\ \hline 1 \ 4 \ \text{oz} \end{array}$$

I subtract 36 ounces from the total of 50 ounces to find how many more ounces of apples Charlie needs to buy. The difference is 14 ounces.

$$14 \text{ oz} = \underline{\hspace{2cm}} \text{ lb}$$

$$\begin{aligned} 14 \text{ oz} &= 14 \times 1 \text{ oz} \\ &= 14 \times \frac{1}{16} \text{ lb} \\ &= \frac{14}{16} \text{ lb} \\ &= \frac{7}{8} \text{ lb} \end{aligned}$$

Since the question asks how many more **pounds** does he need to buy, I convert 14 ounces to pounds.

Charlie needs to buy  $\frac{7}{8}$  pound of apples.



## G5-M4-Lesson 21

Fill in the blanks.

1.  $\frac{3}{5} \times 1 = \frac{3}{5} \times \frac{6}{6} = \frac{18}{30}$

I think 3 times what is 18, and 5 times what is 30? The missing fraction must be  $\frac{6}{6}$ .

I know that any number times 1, or a fraction equal to 1, will be equal to the number itself.

$$\frac{3}{5} = \frac{18}{30}$$

2. Express each fraction as an equivalent decimal.

a.  $\frac{1}{4} \times \frac{25}{25} = \frac{25}{100} = 0.25$

I look at the denominator, 4, and it is a factor of 100 and 1,000.

I can rename  $\frac{1}{4}$  as  $\frac{25}{100}$ , or 0.25.

In order to write a fraction as a decimal, I can rename the denominator as a power of 10 (e.g., 10, 100, 1,000).

$$\frac{1}{10} = 0.1 \quad \frac{1}{100} = 0.01 \quad \frac{1}{1,000} = 0.001$$

b.  $\frac{4}{5} \times \frac{2}{2} = \frac{8}{10} = 0.8$

I look at the denominator, 5, and it is a factor of 10, 100, and 1,000.

c.  $\frac{21}{20} \times \frac{5}{5} = \frac{105}{100} = 1.05$

Since  $\frac{21}{20}$  is a fraction greater than 1, the equivalent decimal must also be greater than 1.

d.  $3\frac{21}{50} \times \frac{2}{2} = 3\frac{42}{100} = 3.42$

I look at the denominator, 50, and it is a factor of 100 and 1,000.

Since  $3\frac{21}{50}$  is a mixed number, the equivalent decimal must be greater than 1.

3. Vivian has  $\frac{3}{4}$  of a dollar. She buys a lollipop for 59 cents. Change both numbers into decimals, and tell how much money Vivian has after paying for the lollipop.

$$\begin{aligned}\frac{3}{4} &= \frac{3}{4} \times \frac{25}{25} \\ &= \frac{75}{100} \\ &= 0.75\end{aligned}$$

I multiply  $\frac{3}{4} \times \frac{25}{25}$  to get  $\frac{75}{100}$ .  $\frac{75}{100}$  of a dollar is equal to \$0.75.

$$59 \text{ cents} = \$0.59$$

$$1 \text{ cent} = \$0.01$$

$$\begin{array}{r} \phantom{\$0.} 6 \phantom{0} 15 \\ \$0. 7 \phantom{0} 5 \\ - \$0. 5 \phantom{0} 9 \\ \hline \$0. 1 \phantom{0} 6 \end{array}$$

I subtract \$0.59 from \$0.75 to find that Vivian has \$0.16 left after paying for the lollipop.

*Vivian has \$0.16 left after paying for the lollipop.*

G5-M4-Lesson 22

1. Solve for the unknown. Rewrite each phrase as a multiplication sentence. Circle the scaling factor, and put a box around the factor naming the number of meters.

a.  $\frac{1}{2}$  as long as 8 meters = 4 meters

$\left(\frac{1}{2}\right) \times \boxed{8 \text{ m}} = 4 \text{ m}$

Half of 8 is 4, so 1 half of 8 meters is 4 meters.

b. 8 times as long as  $\frac{1}{2}$  meter = 4 meters

$\boxed{8} \times \left(\frac{1}{2}\right) \text{ m} = 4 \text{ m}$

2 times 1 half is equal to 1. So 8 times 1 half (or 8 copies of 1 half) is equal to 4.

2. Draw a tape diagram to model each situation in Problem 1, and describe what happened to the number of meters when it was multiplied by the scaling factor.

a.

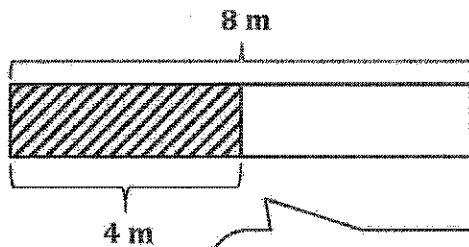

This tape shows a whole of 8 meters. I partition it into 2 equal units to make halves. Half of 8 m is 4 m.

b.

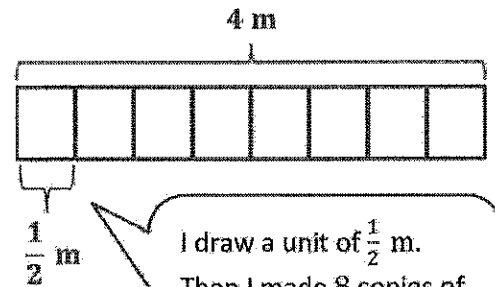

I draw a unit of  $\frac{1}{2}$  m. Then I made 8 copies of it to show  $8 \times \frac{1}{2}$  m, which is equal to 4 m.

In part (a), the scaling factor  $\frac{1}{2}$  is less than 1, so the number of meters decreases.

In part (b), the scaling factor 8 is greater than 1, so the number of meters increases.

3. Look at the inequalities in each box. Choose a single fraction to write in all three blanks that would make all three number sentences true. Explain how you know.

a.

$$\frac{3}{4} \times \frac{4}{2} > \frac{3}{4}$$

$$2 \times \frac{4}{2} > 2$$

$$\frac{7}{5} \times \frac{4}{2} > \frac{7}{5}$$

*Any fraction greater than 1 will work. Multiplying by a factor greater than 1, like  $\frac{4}{2}$ , will make the product larger than the first factor shown.*

Each of these inequalities shows that the expression on the left is greater than the value on the right. Therefore, I need to think of a scaling factor that is greater than 1, like  $\frac{4}{2}$ .

b.

$$\frac{3}{4} \times \frac{1}{3} < \frac{3}{4}$$

$$2 \times \frac{1}{3} < 2$$

$$\frac{7}{5} \times \frac{1}{3} < \frac{7}{5}$$

*Any fraction less than 1 will work. Multiplying by a factor less than 1, like  $\frac{1}{3}$ , will make the product smaller than the first factor shown.*

Each of these inequalities shows that the expression on the left is less than the value on the right. Therefore, I need to think of a scaling factor that is less than 1, like  $\frac{1}{3}$ .

4. A company uses a sketch to plan an advertisement on the side of a building. The lettering on the sketch is  $\frac{3}{4}$  inch tall. In the actual advertisement, the letters must be 20 times as tall. How tall will the letters be on the actual advertisement?

$$\begin{aligned} 20 \times \frac{3}{4} \\ &= \frac{20 \times 3}{4} \\ &= \frac{60}{4} \\ &= 15 \end{aligned}$$

*The letters will be 15 inches tall.*

The letters on the sketch have been scaled down to fit on the page; therefore, the letters on the actual advertisement will be larger. In order to find out how large the actual letters will be, I multiply 20 by  $\frac{3}{4}$  inch.

## G5-M4-Lesson 23

1. Sort the following expressions by rewriting them in the table.

$$\boxed{13.89} \times 1.004$$

$$\boxed{602} \times 0.489$$

$$\boxed{102.03} \times 4.015$$

$$\boxed{0.3} \times 0.069$$

$$\boxed{0.72} \times 1.24$$

$$\boxed{0.2} \times 0.1$$

Since 0,489 is less than 1, if I multiplied it by 602, the answer would be less than 602. I'll put this expression in the column on the left.

The product is less than the boxed number:	The product is greater than the boxed number:
$\boxed{0.3} \times 0.069$ $\boxed{602} \times 0.489$ $\boxed{0.2} \times 0.1$	$\boxed{13.89} \times 1.004$ $\boxed{0.72} \times 1.24$ $\boxed{102.03} \times 4.015$

All of the expressions in this column have a boxed number that is multiplied by a **scaling factor less than 1** (e.g., 0.069 and 0.1). Therefore, the product will be less than the boxed number.

All of the expressions in this column have a boxed number that is multiplied by a **scaling factor more than 1** (e.g., 1.004 and 4.015). Therefore, the product will be greater than the boxed number.

## G5-M4-Lesson 23

1. Sort the following expressions by rewriting them in the table.

$$\boxed{13.89} \times 1.004$$

$$\boxed{602} \times 0.489$$

$$\boxed{102.03} \times 4.015$$

$$\boxed{0.3} \times 0.069$$

$$\boxed{0.72} \times 1.24$$

$$\boxed{0.2} \times 0.1$$

Since 0.489 is less than 1, if I multiplied it by 602, the answer would be less than 602. I'll put this expression in the column on the left.

The product is less than the boxed number:	The product is greater than the boxed number:
$\boxed{0.3} \times 0.069$ $\boxed{602} \times 0.489$ $\boxed{0.2} \times 0.1$	$\boxed{13.89} \times 1.004$ $\boxed{0.72} \times 1.24$ $\boxed{102.03} \times 4.015$

All of the expressions in this column have a boxed number that is multiplied by a **scaling factor less than 1** (e.g., 0.069 and 0.1). Therefore, the product will be less than the boxed number.

All of the expressions in this column have a boxed number that is multiplied by a **scaling factor more than 1** (e.g., 1.004 and 4.015). Therefore, the product will be greater than the boxed number.

2. Write a statement using one of the following phrases to compare the value of the expressions.

*is slightly more than*      *is a lot more than*      *is slightly less than*      *is a lot less than*

a.  $4 \times 0.988$  is slightly less than 4

b.  $1.05 \times 0.8$  is slightly more than 0.8

c.  $1,725 \times 0.013$  is a lot less than 1,725

d.  $89.001 \times 1.3$  is a lot more than 1.3

In this example, the product of  $4 \times 0.988$  is being compared to the factor 4. Since the scaling factor, 0.988, is less than 1, the product will be less than 4. However, since the scaling factor, 0.988, is just **slightly** less than 1, the factor will also be **slightly** less than 4.

In this example, the product of  $89.001 \times 1.3$  is being compared to the factor 1.3. Since the scaling factor, 89.001, is more than 1, the product will be more than 1.3. However, since the scaling factor, 89.001, is **a lot more** than 1, the product will also be **a lot more** than 1.3.

3. During science class, Teo, Carson, and Dhakir measure the length of their bean sprouts. Carson's sprout is 0.9 times the length of Teo's, and Dhakir's is 1.08 times the length of Teo's. Whose bean sprout is the longest? The shortest?

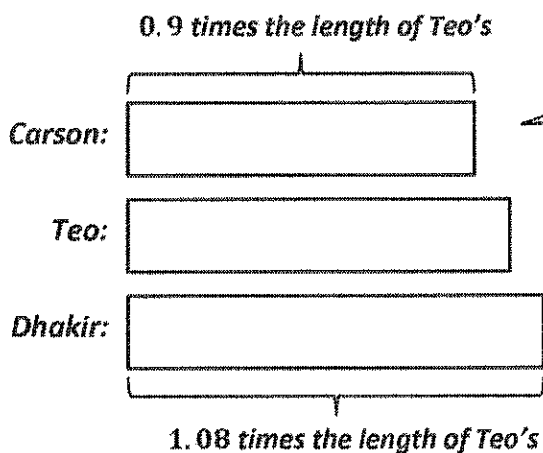

I draw a tape diagram to help me solve.

0.9 is less than 1, so that means Carson's sprout is shorter than Teo's.

1.08 is more than 1, so that means Dhakir's sprout is longer than Teo's.

Dhakir's bean sprout is the longest.  
Carson's bean sprout is the shortest.

## G5-M4-Lesson 24

1. A tube contains 28 mL of medicine. If each dose is  $\frac{1}{8}$  of the tube, how many milliliters is each dose? Express your answer as a decimal.

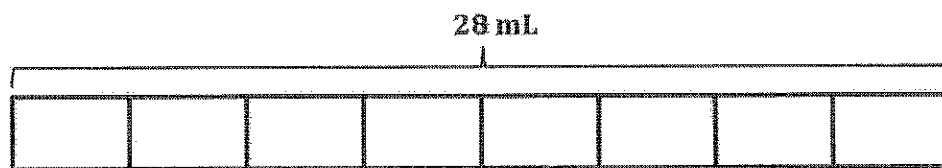

? mL

The whole tube is equal to 28 mL. I can find the value of one unit, or one dose, by either multiplying  $28 \text{ mL} \times \frac{1}{8}$  or by dividing 28 mL by 8.

$$8 \text{ units} = 28 \text{ mL}$$

$$1 \text{ unit} = 28 \text{ mL} \div 8$$

$$= \frac{28}{8} \text{ mL}$$

$$= 3 \frac{4}{8} \text{ mL}$$

$$= 3 \frac{1}{2} \text{ mL}$$

Now I know that each dose is  $3 \frac{1}{2}$  mL, but the problem asks me to express my answer as a decimal. I'll need to find a fraction that is equal to  $\frac{1}{2}$  and has a denominator of 10, 100, or 1,000.

I can multiply the fraction  $\frac{1}{2}$  by  $\frac{5}{5}$  to create an equivalent fraction with 10 as the denominator. Then I'll be able to express  $3 \frac{1}{2}$  as a decimal.

$$\text{Each dose is } 3 \frac{1}{2} \text{ mL.}$$

$$3 \frac{1}{2} \times \frac{5}{5} = 3 \frac{5}{10} = 3.5$$

$$\text{Each dose is } 3.5 \text{ mL.}$$

*Note: Some students may recognize that the fraction  $\frac{1}{2}$  is equal to 0.5 without showing any work. Encourage your child to show the amount of work that is necessary to be successful. If your child can do basic calculations mentally, allow him or her to do so!*



2. A clothing factory uses 1,275.2 meters of cloth a week to make shirts. How much cloth is needed to make  $3\frac{3}{5}$  times as many shirts?

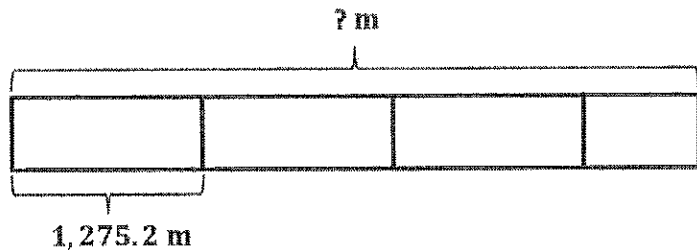

$$1,275.2 \text{ m} = 1,275\frac{2}{10} \text{ m}$$

I can rename 2 tenths meter as a fraction.

My tape diagram reminds me that I can use the distributive property to solve. I can multiply  $1,275\frac{2}{10}$  by 3 first, to find out what 3 times as many shirts is. Then I can multiply by  $\frac{3}{5}$  to find out what  $\frac{3}{5}$  as many shirts is.

$$\begin{aligned} 1,275\frac{2}{10} \times 3\frac{3}{5} &= \left(1,275\frac{2}{10} \times 3\right) + \left(1,275\frac{2}{10} \times \frac{3}{5}\right) \\ &= \left(3,825\frac{6}{10}\right) + \left(\frac{12,752}{10} \times \frac{3}{5}\right) \\ &= \left(3,825\frac{6}{10}\right) + \left(\frac{12,752 \times 3}{10 \times 5}\right) \\ &= \left(3,825\frac{6}{10}\right) + \left(\frac{38,256}{50}\right) \\ &= \left(3,825\frac{6}{10}\right) + \left(765\frac{6}{50}\right) \\ &= \left(3,825\frac{60}{100}\right) + \left(765\frac{12}{100}\right) \\ &= 4,590\frac{72}{100} \\ &= 4,590.72 \end{aligned}$$

I can rename  $\frac{72}{100}$  as 0.72 to express my final answer as a decimal.

In order to add, I make like units, or find common denominators. I'll rename each fraction using hundredths, so I can easily express my final answer as a decimal.

**4,590.72 meters of cloth are needed to make the shirts.**

3. There are  $\frac{3}{4}$  as many boys as girls in a class of fifth graders. If there are 35 students in the class, how many are girls?

I draw a tape to represent the number of girls in the class.

I partition it into 4 equal units to make fourths.

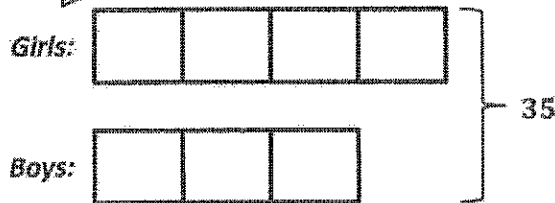

I can think about what my tape diagram is showing. There are a total of 7 units, and those 7 units are equal to a total of 35 students. In order to find out how many girls there are, I need to know the value of 1 unit.

Since there are  $\frac{3}{4}$  as many boys as girls, I draw a tape to represent the number of boys that is  $\frac{3}{4}$  as long as the tape for the number of girls.

$$7 \text{ units} = 35$$

$$1 \text{ unit} = 35 \div 7$$

$$1 \text{ unit} = 5$$

$$4 \text{ units} = 4 \times 5 = 20$$

There are 20 girls in the class.

If each unit is equal to 5 students and there are 4 units representing the girls, I can multiply to find the number of girls in the class.

G5-M4-Lesson 25

1. Draw a tape diagram and a number line to solve.

$$2 \div \frac{1}{2}$$

I can think about this division expression by asking "How many halves are in 2 wholes?"

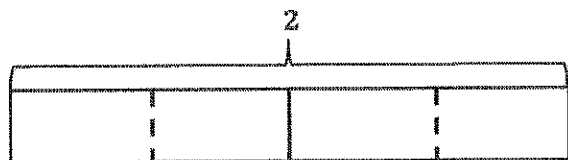

I know that there are 2 halves in 1 whole.

Therefore, there are 4 halves in 2 wholes.

My number line shows the same thing. Since there are 2 halves in 1, there are 4 halves in 2.

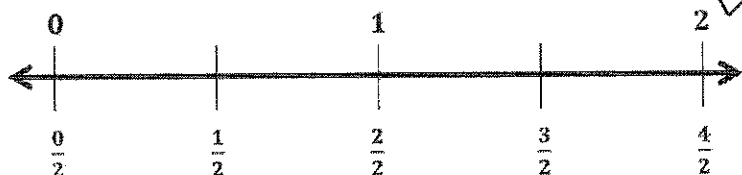

$$2 \div \frac{1}{2} = 4$$

$$2 \div \frac{1}{2}$$

I can also think about this division expression by asking "2 is *half* of what?" or "If 2 is *half*, what is the whole?"

I draw a unit of 2.

And since 2 is half, I draw another unit of 2.

My number line shows the same thing. If 2 is half, 4 is the whole.

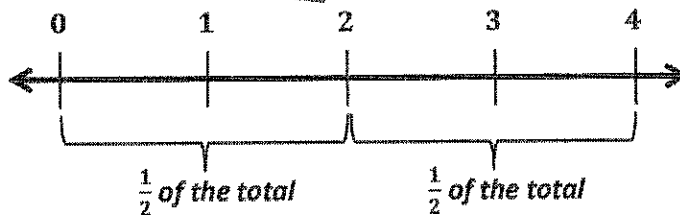
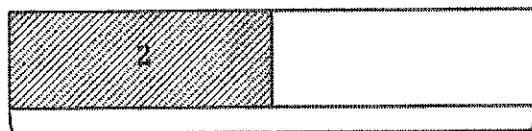

Therefore, if 2 is half, 4 is the whole!

2. Divide. Then multiply to check.

$$2 \div \frac{1}{3}$$

I can think, "How many thirds are in 2?"

There are 3 thirds in 1, so there are 6 thirds in 2.

Or I can think, "If 2 is a third, what is the whole?"

$$2 \div \frac{1}{3} = 6$$

$$\text{Check: } 6 \times \frac{1}{3} = \frac{6 \times 1}{3} = \frac{6}{3} = 2$$

3. A recipe for rolls calls for  $\frac{1}{4}$  cup of sugar. How many batches of rolls can be made with 2 cups of sugar?

This problem is asking me to find how many fourths are in 2.

There are a total of 2 cups of sugar.

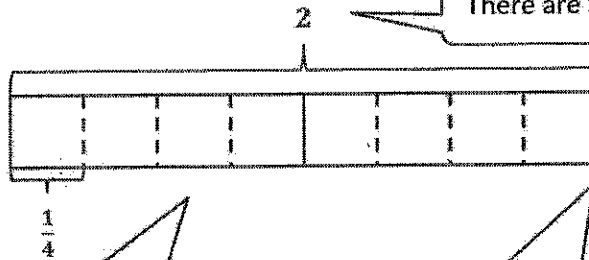

I partition each individual cup of sugar into 4 equal units, called fourths.

Since there are 4 fourths in 1 cup, there are 8 fourths in 2 cups.

$$2 \div \frac{1}{4} = 8$$

8 batches of rolls can be made with 2 cups of sugar.

G5-M4-Lesson 26

1. Solve and support your answer with a model or tape diagram. Write your quotient in the blank.

$$\frac{1}{2} \div 3 = \frac{1}{6}$$

I can think of this expression as "One half of a pan of brownies is shared equally with 3 people. How much of the pan does each person get?"



I can draw a pan of brownies and shade the  $\frac{1}{2}$  of a pan that will be shared.

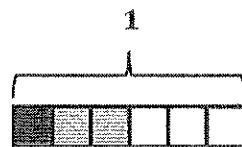

$$\begin{aligned} 1 \text{ half} \div 3 \\ = 3 \text{ sixths} \div 3 \\ = 1 \text{ sixth} \end{aligned}$$

In order to share the brownies with 3 people equally, I partition it into 3 equal parts. I do the same for the other half of the pan so that I can see equal units. Each person will get  $\frac{1}{6}$  of the pan of brownies.

2. Divide. Then, multiply to check.

$$\frac{1}{4} \div 5$$

$$\frac{5}{20} \div 5 = 5 \text{ twentieths} \div 5 = 1 \text{ twentieth} = \frac{1}{20}$$

I can visualize a tape diagram. In my mind, I can see 1 fourth being partitioned into 5 equal units. Now, instead of seeing fourths, the model is showing twentieths.

I know that  $5 \div 5$  is equal to 1.

Therefore,  $5 \text{ twentieths} \div 5 = 1 \text{ twentieth}$ , or  $\frac{1}{20}$ .

$$\text{Check: } \frac{1}{20} \times 5 = \frac{5}{20} = \frac{1}{4}$$

I check my answer by multiplying the quotient,  $\frac{1}{20}$ , and the divisor, 5, to get  $\frac{1}{4}$ .

Since Tim read  $\frac{4}{5}$  of the book, it means he has  $\frac{1}{5}$  left to read.

$$1 - \frac{4}{5} = \frac{1}{5}$$

3. Tim has read  $\frac{4}{5}$  of his book. He finishes the book by reading the same amount each night for 3 nights.

- a. What fraction of the book does he read on each of the 3 nights?

$$\frac{1}{5} \div 3 = \frac{3}{15} \div 3 = \frac{1}{15}$$

I can rename  $\frac{1}{5}$  as  $\frac{3}{15}$ . Then, I divide.

3 fifteenths  $\div$  3 = 1 fifteenth, or  $\frac{1}{15}$ .

He reads  $\frac{1}{15}$  of the book on each of the 3 nights.

- b. If he reads 6 pages on each of the 3 nights, how long is the book?

1 unit = 6 pages

15 units =  $15 \times 6$  pages = 90 pages

Tim reads  $\frac{1}{15}$ , or 6 pages, each night.

So  $\frac{1}{15}$  or 1 unit is equal to 6 pages.

The book has 90 pages.

The whole book is equal to  $\frac{15}{15}$ , or 15 units.  
So I multiply 15 times 6.

G5-M4-Lesson 27

1. Owen ordered 2 mini cakes for a birthday party. The cakes were sliced into fifths. How many slices were there? Draw a picture to support your response.

I draw a tape diagram and label 2 for the 2 mini cakes.

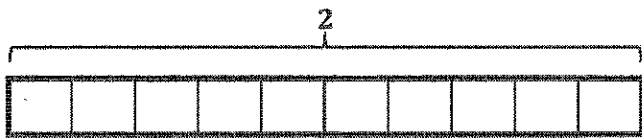

I cut each cake into 5 equal units and get a total of 10 units.

I can think, "How many fifths are in 2?"

5 fifths in 1 cake

10 fifths in 2 cakes

$$2 \div \frac{1}{5} = 10$$

There were 10 slices.

2. Alex has  $\frac{1}{8}$  of a pizza left over. He wants to give the leftover pizza to 3 friends to share equally. What fraction of the original pizza will each friend receive? Draw a picture to support your response.

I draw a tape diagram and label it 1 to represent the whole pizza. I cut it into 8 equal units and shade 1 unit to represent the  $\frac{1}{8}$  that Alex has.

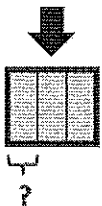
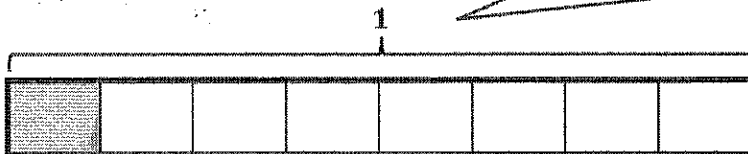

Since the  $\frac{1}{8}$  of a pizza is being shared by 3 friends, I partition the eighth into 3 equal parts. If I did that with the other  $\frac{7}{8}$ , that would make a total of 24 units.

Three friends are sharing  $\frac{1}{8}$  of a pizza. I'll divide  $\frac{1}{8}$  by 3 to find how much each friend will receive.

$$\frac{1}{8} \div 3$$

$$= 1 \text{ eighth} \div 3$$

$$= 3 \text{ twenty-fourths} \div 3$$

$$= 1 \text{ twenty-fourth}$$

Each friend will receive  $\frac{1}{24}$  of a pizza.

One eighth is equal to 3 twenty-fourths. Three twenty-fourths divided by 3 is equal to 1 twenty-fourth.

G5-M4-Lesson 28

My story problem has to be about 4 meters of string.

1. Create and solve a division story problem about 4 meters of string that is modeled by the tape diagram below.

The whole or dividend is 4 meters, and it is being cut into units of  $\frac{1}{3}$  meter. One third is the divisor.

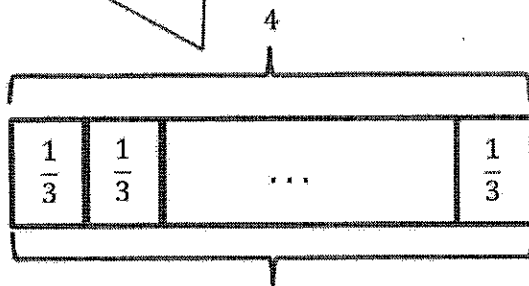

Allison has 4 meters of string. She cuts each meter equally into thirds. How many thirds will she have altogether?

$$4 \div \frac{1}{3} = 12$$

Allison will have 12 thirds.

How many thirds are in 4? I can solve by dividing,  $4 \div \frac{1}{3}$ .

Since there are 3 thirds in 1,  $2 = 6$  thirds,  $3 = 9$  thirds, and  $4 = 12$  thirds. Therefore, 4 divided by  $\frac{1}{3}$  is equal to 12.

2. Create and solve a story problem about  $\frac{1}{3}$  pound of peanuts that is modeled by the tape diagram below.

The dividend,  $\frac{1}{3}$ , is being divided into 4 equal parts. This model shows  $\frac{1}{3} \div 4$ .

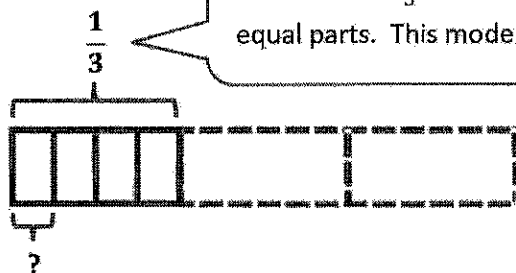

$$\frac{1}{3} \div 4 = \frac{1}{12}$$

There are  $\frac{1}{12}$  pound of peanuts in each bag.

Juanita bought  $\frac{1}{3}$  pound of peanuts. She splits the peanuts equally into 4 bags. How many pounds of peanuts are in each bag?



3. Draw a tape diagram and create a word problem for the following expression, and then solve.

$$2 \div \frac{1}{5} = 10$$

I can interpret this expression as "2 is  $\frac{1}{5}$  of what?"

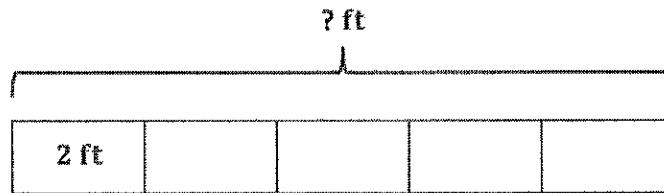

This 2 foot unit is  $\frac{1}{5}$  of the whole. This is what Eddie has finished.

The remaining  $\frac{4}{5}$  are also 2 foot units. Eddie still has 8 more feet to dig.

*After digging a tunnel 2 feet long, Eddie had finished  $\frac{1}{5}$  of the tunnel. How long will the tunnel be when Eddie is done?*

*The tunnel will be 10 feet long.*

## G5-M4-Lesson 29

1. Divide. Rewrite each expression as a division sentence with a fraction divisor, and fill in the blanks.

a.  $4 \div 0.1 = 4 \div \frac{1}{10} = 40$

There are 10 tenths in 1 whole.

There are 40 tenths in 4 wholes.

b.  $3.5 \div 0.1 = 3.5 \div \frac{1}{10} = 35$

There are 10 tenths in 1, so there are 30 tenths in 3.

There are 30 tenths in 3 wholes.

There are 5 tenths in 5 tenths.

There are 35 tenths in 3.5.

c.  $5 \div 0.01 = 5 \div \frac{1}{100} = 500$

There are 100 hundredths in 1 whole.

There are 500 hundredths in 5 wholes.

d.  $2.7 \div 0.01 = 2.7 \div \frac{1}{100} = 270$

There are 100 hundredths in 1, so there are 200 hundredths in 2.

There are 200 hundredths in 2 wholes.

There are 70 hundredths in 7 tenths.

There are 10 hundredths in 1 tenth, so there are 70 hundredths in 7 tenths.

There are 270 hundredths in 2.7.

2. Divide.

a.  $35 \div 0.1$

$$= 35 \div \frac{1}{10}$$

$$= 350$$

I know that there are 10 tenths in 1 and 100 tenths in 10. So there are 350 tenths in 35.

b.  $1.9 \div 0.1$

$$= 1.9 \div \frac{1}{10}$$

$$= 19$$

I can decompose 1.9 into 1 one 9 tenths. There are 10 tenths in 1, and 9 tenths in 9 tenths. Therefore, there are 19 tenths in 1.9.

c.  $3.76 \div 0.01$

$$= 3.76 \div \frac{1}{100}$$

$$= 376$$

I can decompose 3.76 into 3 ones 7 tenths 6 hundredths. 3 ones = 300 hundredths, 7 tenths = 70 hundredths, and 6 hundredths = 6 hundredths.

## G5-M4-Lesson 30

1. Rewrite the division expression as a fraction and divide.

$$\begin{aligned} \text{a. } 6.3 \div 0.9 &= \frac{6.3}{0.9} \\ &= \frac{6.3 \times 10}{0.9 \times 10} \\ &= \frac{63}{9} \\ &= 7 \end{aligned}$$

I can multiply this fraction by 1, or  $\frac{10}{10}$ , to get a denominator that is a whole number.

After multiplying by  $\frac{10}{10}$ , the division expression is 63 divided by 9.

$$\begin{aligned} \text{b. } 6.3 \div 0.09 &= \frac{6.3}{0.09} \\ &= \frac{6.3 \times 100}{0.09 \times 100} \\ &= \frac{630}{9} \\ &= 70 \end{aligned}$$

I can multiply this fraction by 1, or  $\frac{100}{100}$ , to get a denominator that is a whole number.

$$\begin{aligned} \text{c. } 4.8 \div 1.2 &= \frac{4.8}{1.2} \\ &= \frac{4.8 \times 10}{1.2 \times 10} \\ &= \frac{48}{12} \\ &= 4 \end{aligned}$$

$$\begin{aligned} \text{d. } 0.48 \div 0.12 &= \frac{0.48}{0.12} \\ &= \frac{0.48 \times 100}{0.12 \times 100} \\ &= \frac{48}{12} \\ &= 4 \end{aligned}$$

2. Mr. Huynh buys 2.4 kg of flour for his bakery.

- a. If he pours 0.8 kg of flour into separate bags, how many bags of flour can he make?

$$\begin{aligned} 2.4 \div 0.8 &= \frac{2.4}{0.8} \\ &= \frac{2.4 \times 10}{0.8 \times 10} \\ &= \frac{24}{8} \\ &= 3 \end{aligned}$$

I can divide 2.4 kg by 0.8 kg to find the number of bags of flour he can make.

24 divided by 8 is equal to 3.

*He can make 3 bags of flour.*

- b. If he pours 0.4 kg of flour into separate bags, how many bags of flour can he make?

$$\begin{aligned} 2.4 \div 0.4 &= \frac{2.4}{0.4} \\ &= \frac{2.4 \times 10}{0.4 \times 10} \\ &= \frac{24}{4} \\ &= 6 \end{aligned}$$

*He can make 6 bags of flour.*

## G5-M4-Lesson 31

1. Estimate, and then divide.

I can think of multiplying both the dividend (89.6) and the divisor (0.8) by 10 to get  $896 \div 8$ .

$$a. \quad 89.6 \div 0.8 \approx 880 \div 8 = 110$$

$$= \frac{89.6}{0.8}$$

$$= \frac{89.6 \times 10}{0.8 \times 10}$$

$$= \frac{896}{8}$$

$$= 112$$

I can multiply this fraction by 1, or  $\frac{10}{10}$ , to get a denominator that is a whole number.

I use the long division algorithm to solve 896 divided by 8. The answer is 112, which is very close to my estimated answer of 110.

$$\begin{array}{r} 112 \\ 8 \overline{) 896} \\ \underline{- 8} \phantom{0} \\ 09 \\ \underline{- 8} \phantom{0} \\ 16 \\ \underline{- 16} \\ 0 \end{array}$$

I'll imagine multiplying both the dividend and the divisor by 100 to get  $524 \div 4$ .

$$b. \quad 5.24 \div 0.04 \approx 400 \div 4 = 100$$

$$= \frac{5.24}{0.04}$$

$$= \frac{5.24 \times 100}{0.04 \times 100}$$

$$= \frac{524}{4}$$

$$= 131$$

I can multiply this fraction by 1, or  $\frac{100}{100}$ , to get a denominator that is a whole number.

524 divided by 4 is equal to 131.

$$\begin{array}{r} 131 \\ 4 \overline{) 524} \\ \underline{- 4} \phantom{0} \\ 12 \\ \underline{- 12} \phantom{0} \\ 04 \\ \underline{- 4} \\ 0 \end{array}$$

2. Solve using the standard algorithm. Use the thought bubble to show your thinking as you rename the divisor as a whole number.

$$2.64 \div 0.06 = 44$$

*I multiplied 2.64 and 0.06 by 100 to get an equivalent division expression with whole numbers.*

$$2.64 \div 0.06 = \frac{264}{6}$$

I write a note explaining how I can rewrite the division expression from  $2.64 \div 0.06$  to  $264 \div 6$ . Both expressions are equivalent.

$$\begin{array}{r} 44 \\ 6 \overline{) 264} \\ \underline{- 24} \phantom{0} \\ 24 \\ \underline{- 24} \\ 0 \end{array}$$

I solve by using the long division algorithm,  $264 \div 6 = 44$ .

G5-M4-Lesson 32

1. Circle the expression equivalent to *the sum of 5 and 2 divided by  $\frac{1}{5}$* .

$$\frac{5 + 2}{5}$$

This expression represents the sum of 5 and 2 divided by 5.

$$5 + \left(2 \div \frac{1}{5}\right)$$

This expression represents the sum of 5 and the quotient of 2 divided by  $\frac{1}{5}$ .

$$\frac{1}{5} \div (5 + 2)$$

This expression represents  $\frac{1}{5}$  divided by the sum of 5 and 2.

$$(5 + 2) \div \frac{1}{5}$$

This expression is equivalent to the sum of 5 and 2 divided by  $\frac{1}{5}$ .

2. Fill in the chart by writing an equivalent numerical expression.

I can find "half" by dividing by 2 or by multiplying by  $\frac{1}{2}$ .

The *difference* between two numbers means I need to use subtraction to solve.

This is one possible way to write the numerical expression.

a.	Half as much as the difference between $1\frac{1}{4}$ and $\frac{5}{8}$	$\left(1\frac{1}{4} - \frac{5}{8}\right) \div 2$
b.	Add 3.9 and $\frac{5}{7}$ , and then triple the sum.	$\left(3.9 + \frac{5}{7}\right) \times 3$

Add two numbers means I need to use addition.

I can triple a number by adding it 3 times or by multiplying by 3.



3. Fill in the chart by writing an equivalent expression in word form.

I see the subtraction sign, so I use the phrase, "difference between  $\frac{3}{5}$  and \_\_\_\_\_."

I see the multiplication sign, so I use the phrase "product of  $\frac{1}{4}$  and 2 tenths."

a.	The difference between $\frac{3}{5}$ and the product of $\frac{1}{4}$ and 2 tenths	$\frac{3}{5} - (\frac{1}{4} \times 0.2)$
b.	$\frac{3}{2}$ times the sum of 2.75 and $\frac{1}{8}$	$(2.75 + \frac{1}{8}) \times \frac{3}{2}$

I see the addition sign, so I use the phrase "sum of 2.75 and  $\frac{1}{8}$ ."

I see the multiplication symbol, so I say, " $\frac{3}{2}$  times."

Evaluate means to "find the value of."

4. Evaluate the following the expression.

I see two multiplication signs in this expression, so I can solve for it from left to right. But since multiplication is associative, I can solve  $\frac{4}{9} \times \frac{9}{4}$  first because I can see that the product is 1.

$$\frac{1}{2} \times \frac{4}{9} \times \frac{9}{4}$$

I put a parenthesis around  $\frac{4}{9} \times \frac{9}{4}$  to show that I solve it first.

$$= \frac{1}{2} \times \left( \frac{4}{9} \times \frac{9}{4} \right)$$

$\frac{4}{9} \times \frac{9}{4}$  is equal to  $\frac{36}{36}$ , or 1.

$$= \frac{1}{2} \times 1$$

$$= \frac{1}{2}$$

$\frac{1}{2}$  of 1 is  $\frac{1}{2}$ .

## G5-M4-Lesson 33

I can represent this story with the expression  $\frac{1}{4} \div 3$ .

1. Mrs. Brady has  $\frac{1}{4}$  liter of juice. She distributes it equally to 3 students in her tutoring group.

- a. How many liters of juice does each student get?

$$\frac{1}{4} \div 3$$

I can rename 1 fourth as 3 twelfths, so dividing by 3 is easier.

$$= 1 \text{ fourth} \div 3$$

$$= 3 \text{ twelfths} \div 3$$

3 twelfths divided by 3 is 1 twelfth.

$$= 1 \text{ twelfth}$$

Each student gets  $\frac{1}{12}$  liter of juice.

- b. How many more liters of juice will Mrs. Brady need if she wants to give each of the 36 students in her class the same amount of juice found in Part (a)?

$$36 \times \frac{1}{12} \text{ liter}$$

I can multiply to find how much juice she'll need to serve 36 students.

$$= \frac{36 \times 1}{12} \text{ liters}$$

$$= \frac{36}{12} \text{ liters}$$

Mrs. Brady will need 3 liters of juice for 36 students.

$$= 3 \text{ liters}$$

$$3 \text{ liters} - \frac{1}{4} \text{ liter} = 2 \frac{3}{4} \text{ liters}$$

I subtract to find out how much more juice she'll need.

Mrs. Brady will need an additional  $2 \frac{3}{4}$  liters of juice.

2. Austin buys \$16.20 worth of grapefruit. Each grapefruit costs \$0.60.

- a. How many grapefruits does Austin buy?

$$\$16.20 \div \$0.60$$

$$= \frac{16.2}{0.6} \times \frac{10}{10}$$

$$= \frac{162}{6}$$

$$= 27$$

To find how many grapefruits Austin buys, I use the total cost divided by the cost of each grapefruit.

I multiply the fraction by 1, or  $\frac{10}{10}$ , to get a denominator that is a whole number.

$$\begin{array}{r} 27 \\ 6 \overline{) 162} \\ \underline{- 12} \phantom{0} \\ 42 \\ \underline{- 42} \\ 0 \end{array}$$

I use the long division algorithm to solve 162 divided by 6. The answer is 27.

*Austin buys 27 grapefruits.*

- b. At the same store, Mandy spends one third as much money on grapefruit as Austin. How many grapefruits does she buy?

$$27 \div 3 = 9$$

Since Mandy spent  $\frac{1}{3}$  as much money on grapefruit as Austin, that means she's buying  $\frac{1}{3}$  the number of grapefruit.

*Mandy buys 9 grapefruits.*

To find one third of a number, I can multiply by  $\frac{1}{3}$  or divide by 3.